

## TRB Series

- › *Reliable*
- › *Efficient*
- › *Damage-free*
- › *Flexible*

• Ideal for Shelf Ready Packaging, stacks of laundry and more!



The Bandall TRB series conveys products into the banding arch using motorised conveyor belts. These conveyor belts can be low friction or high friction, depending on the type of product to be banded.

The TRB conveyor belts are available in various lengths and widths

### Fully automatic and budget-friendly banding

This equipment is ideal for easy and budget-friendly banding of trays, multi-packs or stacks of products. Sturdy, reliable and efficient, often used for products with a flat and rigid base.

#### Product detection

The product to be banded is transferred from an existing conveying system and conveyed into the arch. The conveyor stops when the product has been detected by a sensor and the product is automatically banded. If required, a second adjustable sensor can be added for double banding. When banding is complete, the conveyor restarts and the banded product is conveyed out of the arch. The speed of the two conveyor lines can be set individually. On the in-feed side the installation has two product guides which accurately position the product to be banded before it enters the banding arch.



# Easy to operate and to add to

*The Bandall TRB is a successful innovation based on the unique Bandall banding equipment. With a modular construction, the TRB can easily be extended with additional functions, such as presses and printers. The TRB is also available in stainless steel.*

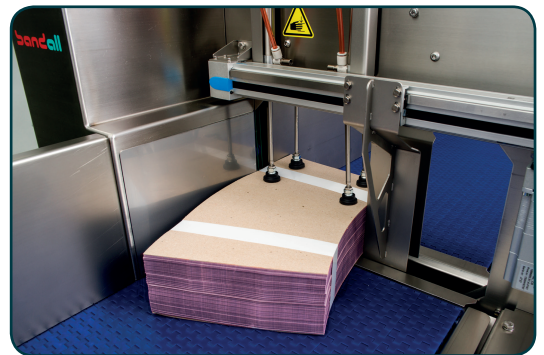
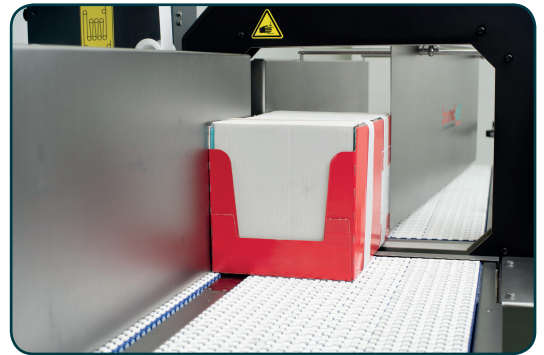

## Immediate benefits

- › **fully automatic** in and out feed
- › **immense savings** in packaging material
- › **taping, gluing and sealing** machines are often rendered redundant
- › **major savings** in energy costs
- › supplied with **multi connector** for signal exchange
- › **limited space** required
- › easily **adjustable** and **portable**

## Bandall TRB Series features

- › **ideal** for 'end of line' use
- › **fully adjustable** belt tension
- › **several bands** per product or tray possible
- › **lowest cost** of ownership

The TRB series is available for processing banding material in many widths from 28 to 125 mm and with a wide choice of arch sizes.

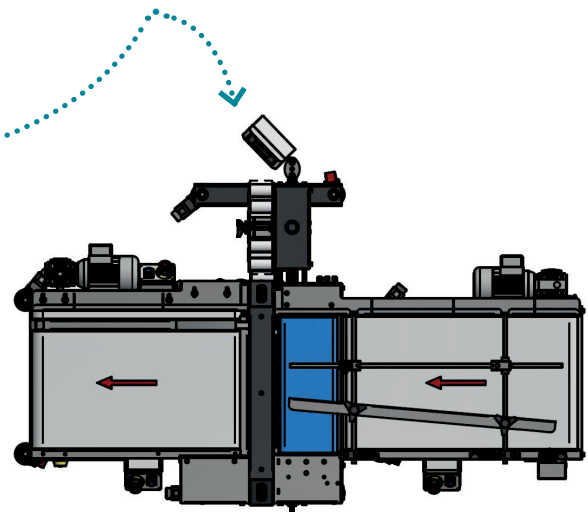
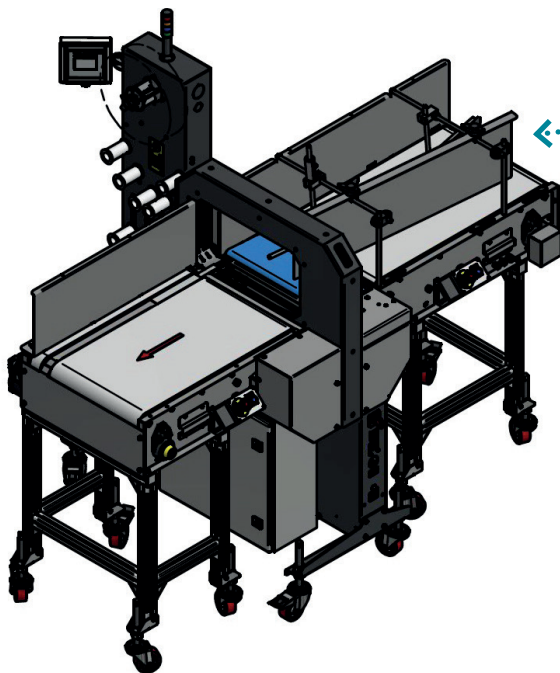

**bandall**<sup>®</sup>  
THE STANDARD IN BANDING

E&OE