

MOSCA®

EXCELLENCE IN STRAPPING SOLUTIONS

EVOLUTION

Intelligent high-end machine



SONIXs TAI-6 PRO
Fully Automatic Cross Strapping System

SoniXs TAI-6 PRO

THE SYSTEM CONSIST OF:

Strapping machine SoniXs TR-6 PRO
Strapping machine SoniXs TRI-6 PRO

STANDARD FEATURES

- Cross strapping without bundle turning
- Ultrasonic sealing system with electronic self-calibration
- Can be integrated into most production lines
- High-end Standard 6 sealing unit
- Easy accessibility and tool-free disassembly of strap way components
- Bundle positioning via increments by metrical input of the strapping positions
- Optimization of the strapping processes by machine adaptation to defined package dimensions
- Intuitive user guidance via colored touch panel. Division into different user groups
- Setting of the strapping positions via visual display in the strapping editor
- Potential-free contacts to up-stream and down-stream systems
- Open design without protective coverings - CE marking inclusive conformity declaration
- Fast, uncomplicated software update via internet possible
- Extremely low energy consumption

OPTIONS

- Energy-efficient, electro-mechanical package stop (also available as pneumatic version)

- Automatic machine adaptation to package dimensions to optimize the strapping process via sensors or interface signals
- Option TR-6 PRO: Energy-efficient, electro-mechanical hold-down device (also available as pneumatic version)
- Variably assignable signal exchange in inlet and outlet
- Machine control via package complementary data by network communication
- Best product processing by possible assignment of package-depending machine settings via product formulations
- Language-independent data. Help texts in many languages

TECHNICAL DATA

PERFORMANCE:

Up to 37 packages per minute (600 x 600 mm, TR-6 PRO)
(500 x 500 mm, TRI-6 PRO)

STRAPS:

Standard machine grade 5 or 9 mm wide PP straps

STRAP COIL DISPENSER:

Core diameter: 200 mm
Core width: 190 mm

ELECTRICITY:

Network data: 100-240 V, 50/60 Hz, 1 Ph*
Power consumption: 0.60 kW

WEIGHT:

805 kg (600 x 600 mm TR-6 PRO and 500 x 500 mm TRI-6 PRO incl. hold-down device & package stop)

* Country-specific adaption possible

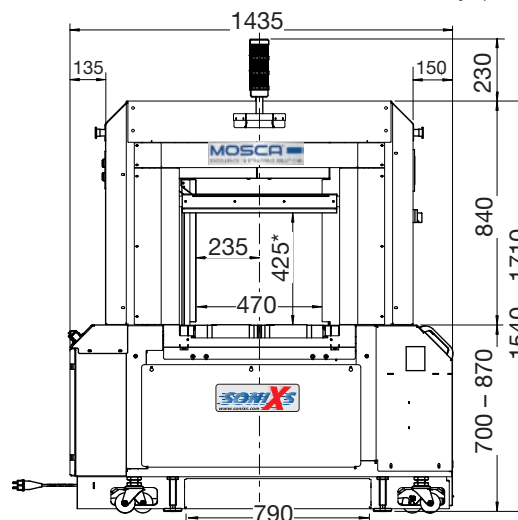
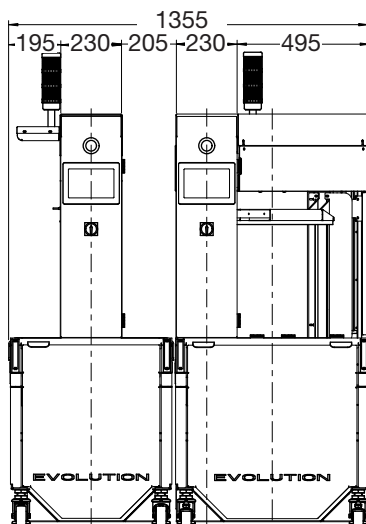

* 400 mm by pneumatic hold-down device



MOSCA[®]
EXCELLENCE IN STRAPPING SOLUTIONS

MOSCA GMBH

Gerd-Mosca-Straße 1
D-69429 Waldbrunn/Germany
Tel.: +49 6274/932-0
Fax: +49 6274/932-400 118
Tel. Tech. Service: +49 6274 / 932-146
E-Mail: info@mosca.com
Internet: www.mosca.com

03/14 Subject to Alterations

The models of SoniXs TAI-6 PRO are adjustable to one strap width of all quality PP straps 5 or 9 mm. Obtainable directly from Mosca, produced in one of Europe's most modern manufacturing plants. Combinable with maintenance contracts by Mosca – a one-stop solution.

