

MOSCA®

EXCELLENCE IN STRAPPING SOLUTIONS

EVOLUTION



SONIXs MP-6 R-VA
Fully Automatic Stainless Steel
Strapping Machine

SoniXs MP-6 R-VA

MACHINE DESCRIPTION

- Corrosion-free ultrasonic sealing system with electronic self-calibration
- High-end Standard 6 sealing unit
- Easy accessibility and tool-free disassembly of strap path components
- Wear-free DC drives with integrated electronics
- Stepless turnable control panel for many-sided operation
- Adjustable strap tension via potentiometer
- Switching from maximum to material-friendly Eco-speed in the control
- Quick strap coil change
- Strap coil changeable from the front and the side
- Automatic strap threading system
- Strap end detection with ejection of remaining strap
- Automatic strap loop ejection
- Extremely low energy consumption
- 4 castors, 2 of them lockable
- CE marking inclusive conformity declaration
- Potential-free contacts to upstream and downstream machines
- Signal-regulated conveying speed from 0-1 m/s
- Parameter control panel for setting strapping parameters

- Selector switch for pass, single, double or multiple strapping
- Machine completely corrosion-free (use of stainless steel or corrosion-free materials, for example V2A, V4A aluminum)
- IP 56 protection class design
- Sensitive components (e.g. motors) are equipped with additional covers

OPTIONS

- Cost-efficient, pneumatic hold-down device
- Automatic adjustment of the strap tension by package height detection
- Lowering chassis H = 730 mm – 835 mm
- Safety spring-up roll at table in- and outfeed
- Product cover identification device (no strapping without top cover)
- Brush guide
- Low strap detection with signal in the control panel
- Signal light
- Emergency stop interface

TECHNICAL DATA:

PERFORMANCE:	Up to 35 cycles/minute
FRAME SIZE:	600 mm x 600 mm
WORKING HEIGHT:	820 mm to 925 mm
STRAPS:	Standard machine grade 5, 6, 8, 9, 10 or 12 mm wide PP straps
STRAP COIL DISPENSER:	Core diameter: 200 mm Core width: 190 mm Max. outer diameter: 430 mm
ELECTRICITY:	Network data: 230 V, 50/60 Hz, 1 Ph Schuko plug Power consumption: approx. 0.25 kW
WEIGHT:	260 kg

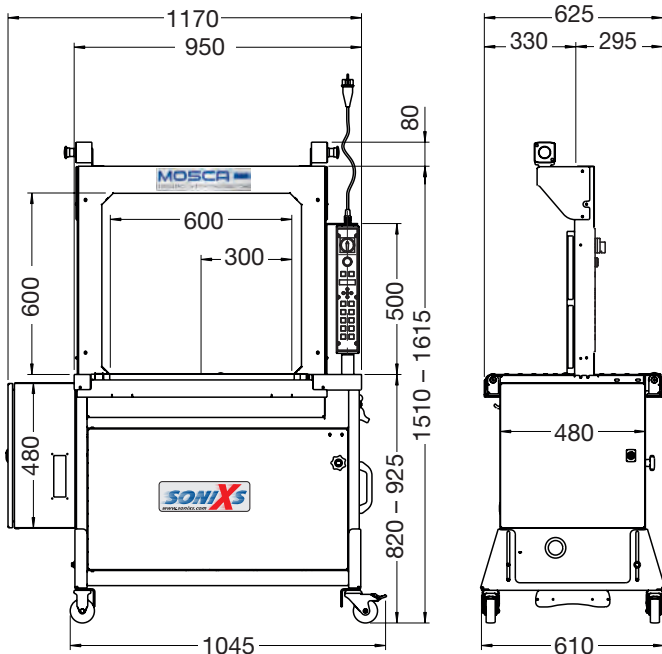

MOSCA[®]
EXCELLENCE IN STRAPPING SOLUTIONS

MOSCA GMBH

Gerd-Mosca-Straße 1
D-69429 Waldbrunn/Germany
Tel.: +49 6274/932-0
Fax: +49 6274/932-400 118
Tel. Tech. Service: +49 6274 / 932-146
E-Mail: info@mosca.com
Internet: www.mosca.com

04 / 16 Subject to alterations

The models of SoniXs MP-6 R-VA are adjustable to one strap width of 5, 6, 8, 9, 10 or 12 mm quality PP straps. Obtainable directly from Mosca, produced in one of Europe's most modern manufacturing plants. Combinable with maintenance contracts by Mosca – a one-step solution.

