

# MOSCA®

EXCELLENCE IN STRAPPING SOLUTIONS



## Evolution SoniXs MS-6-VA

Automatic Stainless Steel Side-Seal Strapping Machine

# SONIXS MS-6-VA

## STANDARD FEATURES

- Corrosion-resistant ultrasonic sealing system with electronic self-calibration
- Can be integrated into most production lines
- High-end Standard 6 sealing unit
- Easy accessibility and tool-free disassembly of strap path components
- Dispenser variably mountable
- Hinged table top made of stainless steel
- Adjustable strap tension via control panel
- Easy operation via digital display in the control panel
- Manual strapping release via pushbutton in the control panel
- Stepless turnable control panel (0°-180°) for two-sided operation
- Machine completely corrosion-resistant (main use of V4A stainless steel)
- 4 castors (Ø 125 mm)
- Extremely low energy consumption
- IP 56 protection class design
- Sensitive components (e.g. motors) are equipped with additional covers

## OPTIONS

- Flexible foot switch for manual strap release
- Pneumatic hold-down device
- Pneumatic side-pusher
- Automatic adjustment of the strap tension by package height detection
- 2- or 3-part signal light
- Low strap detection with signal in the control panel
- Signal exchange via 16-pole contact plug to integrate into fully automatic production lines
- Fully automatic strap coil change by double strap dispenser
- Special conveying heights

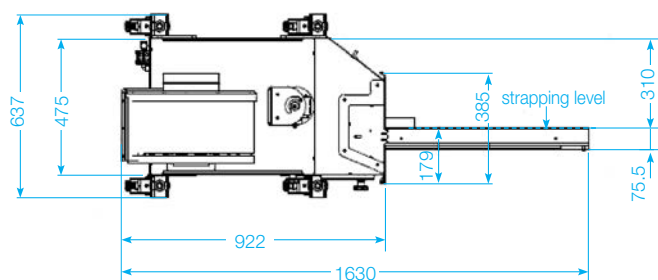

Frame size (650 mm x 600 mm)

\* Picture with options

## TECHNICAL DATA

### PERFORMANCE:

Up to 52 cycles per minute at a frame size of 550 mm x 500 mm

### FRAME SIZES (W x H):

550 mm x 500 mm  
650 mm x 600 mm

### CONVEYING HEIGHTS:

330 mm to 580 mm  
380 mm to 930 mm (optionally increased working height)  
210 mm to 330 mm (optionally lower working height)

### STRAPS:

Standard machine PP straps: Width 5 – 12 mm,  
Thickness 0.4 – 0.8 mm  
(optionally) PET straps: Width 9.5 and 12 mm,  
Thickness 0.54 mm

### STRAP COIL DISPENSER:

Core diameter: 200 mm (optionally 406 mm PET)  
Core width: 190 mm (optionally 150 mm PET)

### ELECTRICITY:

Network data: 100-240 V, 50/60 Hz,  
1L+N+PE

Power consumption: approx. 0.2 kW

### WEIGHT:

250 kg – 400 kg

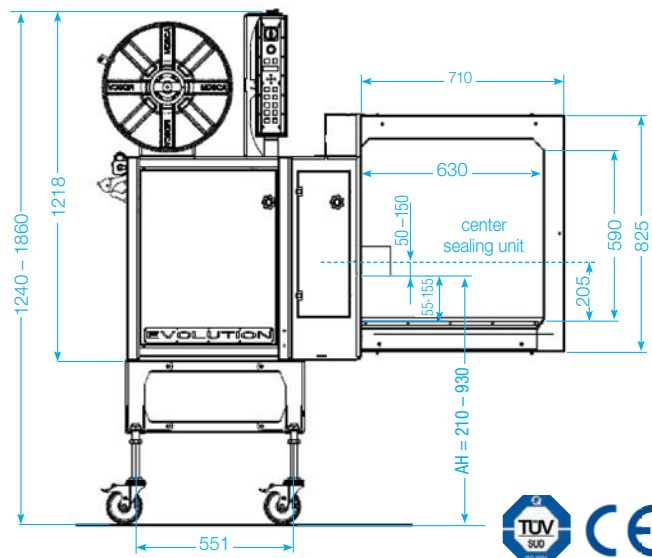

**MOSCA**<sup>®</sup>  
EXCELLENCE IN STRAPPING SOLUTIONS

### MOSCA GMBH

Gerd-Mosca-Straße 1  
D-69429 Waldbrunn/Germany  
Tel.: +49 6274/932-0  
Fax: +49 6274/932-400 118  
Tel. Tech. Service: +49 6274 / 932-146  
E-Mail: info@mosca.com  
Internet: www.mosca.com

03 / 18 Subject to Alterations

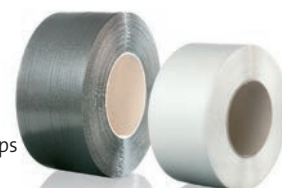

The models of MS-6-VA are adjustable to one strap width of all quality PP- straps from 5 to 12 mm and PET- straps of 9.5 or 12 mm. Obtainable directly from Mosca, produced in one of Europe's most modern manufacturing plants. Combinable with maintenance contracts by Mosca – a one-stop solution.